

Datasheet



**Combined Screening and Degritting Unit**

+49 163 7037447

info@ptech-gmbh.com • www.ptech-gmbh.com



## Equipment Description

The Compact Units made under the manufacturing of Ptech GmbH is a compact system developed to separate large materials, sand and grease from domestic and industrial wastewater. The compact system ensures particles are separated with high efficiency. It requires less maintenance and is easy to operate.

For operational safety reasons, generally the first step in sewage treatment works is usually mechanical pretreatment of wastewater.



## Design and Function

- Fine Screening
- Screening Process
- Grit Separation
- Grit Removal and Discharge
- Grease Separation and Removal



## Usage Areas

- Municipal Wastewater Treatment Plants
- Industrial Wastewater Treatment Plants
- Beverage Industries
- Slaughterhouses
- Paper Mill Industries
- Textile Industry
- Fish Industry
- Food and Chemical Industries
- Plastic Recycling Industries

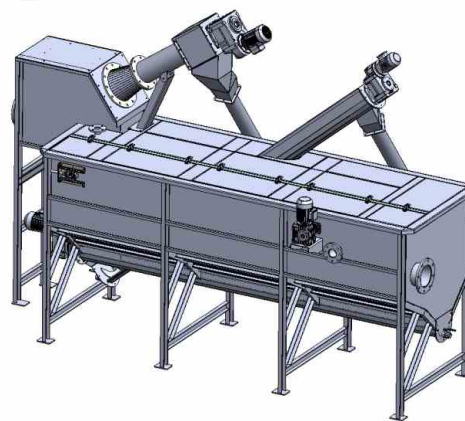
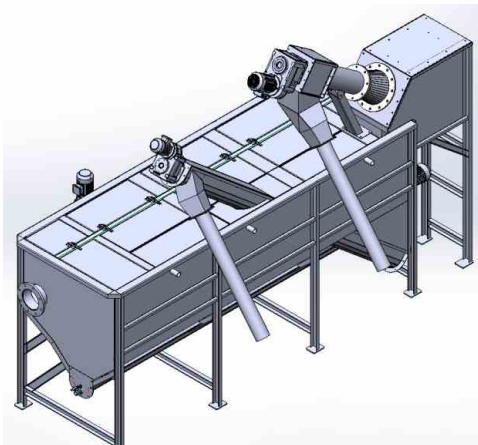

# Ptech

ENERGY - WATER - SEWAGE TREATMENT TECHNOLOGY

## Umwelttechnik GmbH



+49 163 7037447  
info@ptech-gmbh.com  
Katzwanger Str. 150, 90461  
Nürnberg, Germany

📷 ptechgmbh  
🌐 Ptech Umwelttechnik GmbH  
📺 @PtechGmbH

[www.ptech-gmbh.com](http://www.ptech-gmbh.com)